



RACKING-UK

email: sales@racking-uk.com
www.racking-uk.com

Shelving + Racking Specialists

 **08700 706607**

Modular **TRAFFIC BARRIER**

Robust

Impact Resistant

Economic



- ✓ **Easy installation**
- ✓ **Low Maintenance**
- ✓ **Easily repairable**
- ✓ **Strong & Durable**
- ✓ **Impact Resistant**
- ✓ **Long Lifetime**
- ✓ **No Rusting or Rotting**
- ✓ **No Painting**
- ✓ **No screws or welding needed for assembly**

Providing protection for machinery, equipment, materials and buildings in areas where fork lift and other vehicle traffic is present. Ideal for use in definition of vehicle traffic ways and situations where traffic segregation is required.

The barrier is suitable for internal and external use and is supplied with manufacturers recommended floor fixings. When correctly installed in uncracked concrete the fixings provide 90° shear loads of up to 9.8kN

As with other IntaLockBarrier® products the low level barrier is economic and effective and offers the user many benefits including:

**THERE IS NO
SPACE TOO BIG
TOO SMALL
OR TOO
AWKWARD!**



As with other IntaLockBarrier® products the Traffic Barrier has been designed to comply with relevant safety standards and regulations.

The barrier provides high impact resistance and will usually return to its original shape and form after impact without the need for repair or replacement.

To ensure optimum installation and performance the manufacturers recommended post fixing bolts are supplied as standard with the barrier.

The impact height centre of the barrier provides more than adequate protection for equipment and structures

where necessary, should however the main purpose of the barrier be to delineate the boundaries intended for vehicular traffic a lower version of the barrier is available.

The decrease in impact height gives the barrier a lower centre of gravity offering greater resistance to any vehicle straying from its designated traffic way before damage can be caused.

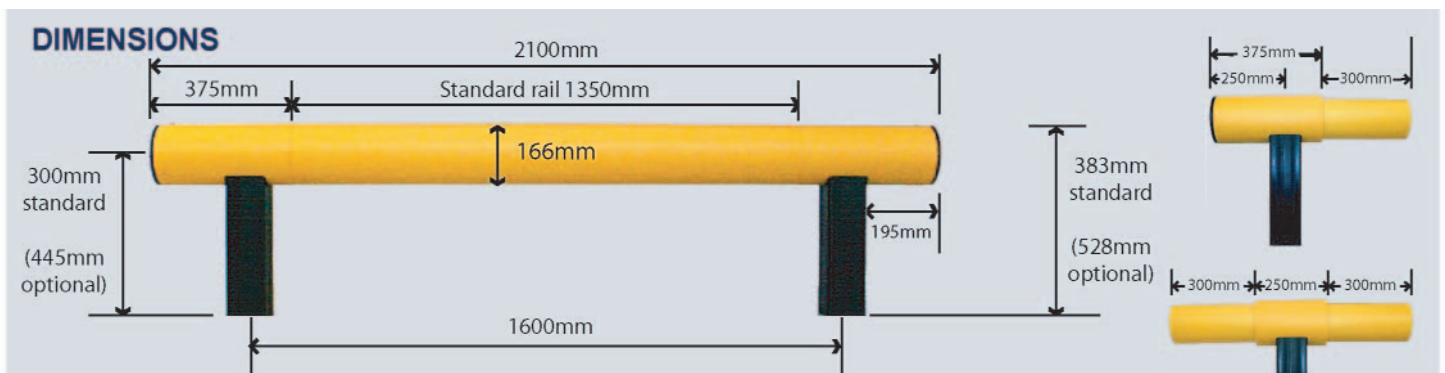
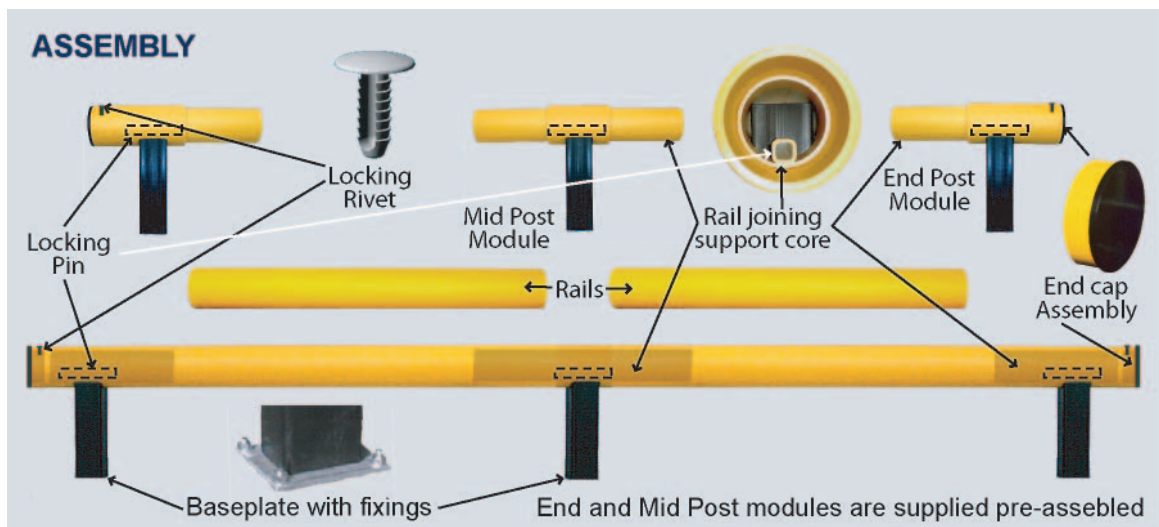

The dimensions given are for a standard 2.1m barrier section. The barrier is available with impact height centres of 300mm or 445mm. Unless requested otherwise 300mm impact height will be supplied. Post sections are 110 x 110 mm and standard rail length is 1350mm. Short rails (600 - 1349mm) and long rails (1.351 - 1.75m) are also available.

THERE IS NO SPACE TOO BIG TOO SMALL OR TOO AWKWARD!